



Trane TVR™ II DC Inverter System

*Innovation for superior efficiency and
all year-around comfort*



Ingersoll Rand (NYSE:IR) advances the quality of life by creating and sustaining safe, comfortable and efficient environments. Our people and our family of brands—including Club Car®, Ingersoll Rand®, Schlage®, Thermo King® and Trane®—work together to enhance the quality and comfort of air in homes and buildings; transport and protect food and perishables; secure homes and commercial properties; and increase industrial productivity and efficiency. We are a \$14 billion global business committed to a world of sustainable progress and enduring results.

Trane has a policy of continuous product & product data improvement and reserves the right to change design & specifications without notice.

www.ingersollrand.co.in , www.traneindia.com



We are committed to using environmentally
conscious print practices that reduce waste.



We are Trane, global leaders in heating, ventilation and air conditioning (HVAC) systems. Our legacy of trust and innovation is what we bring to Indian homes. We always keep introducing revolutionary and technologically evolved products that promise a new level of comfort, convenience & control at your fingertips.

In the league of coming up with new innovations, we bring a new generation of Trane TVR™ II DC Inverter System, a modular system embodied with most advanced architectural concepts and leading technology in providing an ideal environment in villas, condominiums and residences.

The TVR II system sets a new standard in meeting the end user's highest expectations by providing the best in class high energy efficiency level with up to 4.24EER and sheer reliability. Along with the excellent performance it is also committed to be environmentally responsible by using R410A, the refrigerant with zero ozone depletion potential, eco-design, waste reduction etc.

Comfort, convenience and control at your fingertips



Trane TVR™ II DC Inverter System Line-up

Indoor Units	KBtu/Hr																				
	6	7	9	12	15	18	24	27	30	34	38	42	48	55	68	85	95	136	154	191	
One Way Cassette			●	●	●	●															
Two Way Cassette		●	●	●	●	●															
Compact Four Way Cassette		●	●	●	●																
Four Way Cassette						●	●	●	●	●	●	●	●								
Low Static Concealed	●	●	●	●	●	●															
Mid Static Concealed		●	●	●	●	●	●	●	●	●	●	●	●								
High Static Concealed							●	●	●	●	●	●	●	●	●	●	●	●	●	●	●
High Wall		●	●	●	●	●	●	●													
Fresh Air Units												●	●		●	●					

Outdoor Units	KBtu/Hr									
	40	48	55	86	96	115	140	155	171	191
TVR II Mini	●	●	●							
TVR II				●	●	●	●	●	●	●



Superior Efficiency

Less Carbon, more efficiency

TVR™ II System with highly efficient DC compressor and DC fan motor achieves an EER of up to 4.24 (8HP) thereby offering best in class energy efficiency.

• High Efficiency Full DC Inverter Compressor Technology

TVR™ II System achieves the industry's highest energy efficient levels by utilizing the brushless reluctance DC compressor control, DC fan motor and improved performance heat exchanger. It saves power consumption by 25%.



- ✓ New structure-enhanced mid-frequency performance
- ✓ Smooth 180° Sine wave DC inverter
- ✓ New designed scroll profile for R410A
- ✓ More compact with 50% weight reduction
- ✓ Low noise and reduced vibration
- ✓ Improved oil lubrication system
- ✓ Advanced permanent magnet DC motor improves the low frequency band performance
- ✓ Internal oil circulation
- ✓ Liquid return protection

Powerful magnets provide high torque and efficiency and achieve 70% reduction in volume.

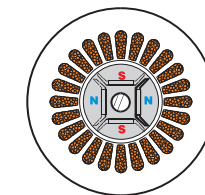

Centralized winding

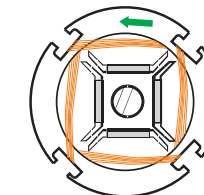

Distributed winding

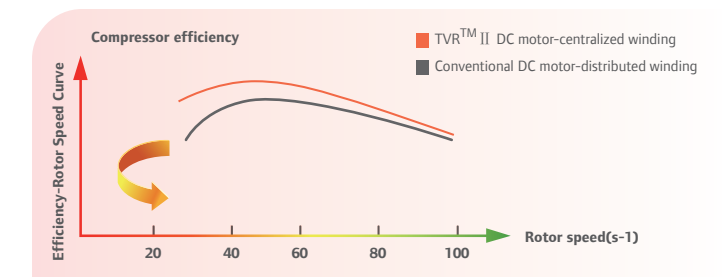

• DC Fan Motor

It checks running load and pressure, and then accordingly controls the speed of DC fan to achieve the minimum power consumption.

This improves efficiency by up to 45% especially at low speed. Optimized fan blade shape with new air outlet grille greatly improves the performance of the fan without increasing the noise levels.



DC Motor

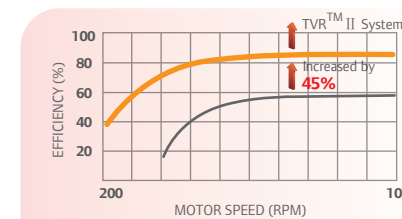

18 steps vector control

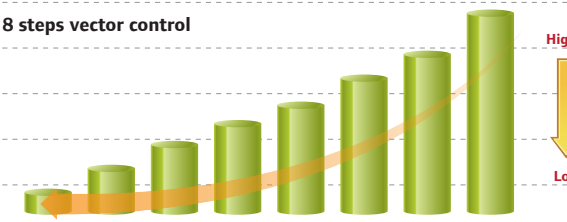

• Enhanced Rated Heating Capacity

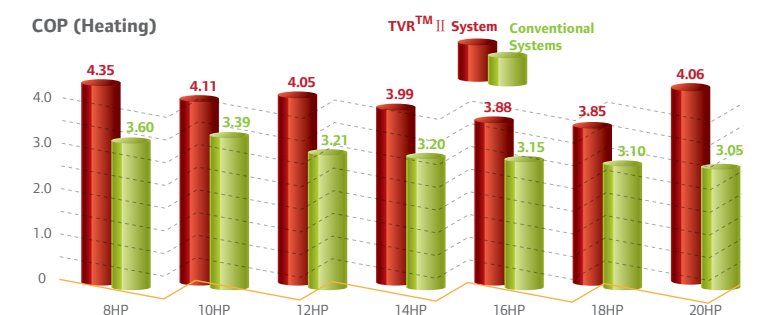
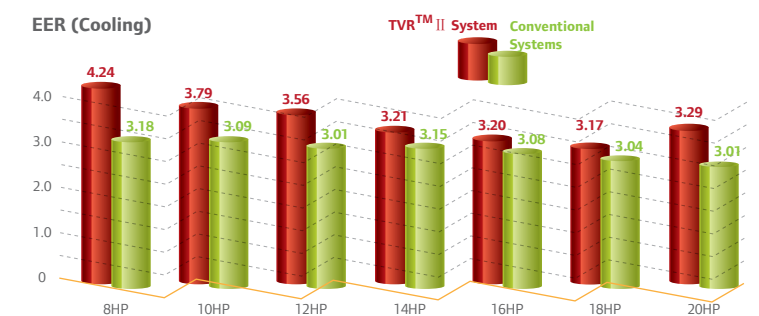

Superior Efficiency

Less Carbon, more efficiency

• Intelligent Soft Start Technology

The soft start function of DC Inverter Compressor reduces strike to electric network. This is a high-performance and low noise scroll compressor, which operates at a faster rate while starting, eventually reducing start-up time. It helps the unit to bring the room temperature up to the set level much more quickly.

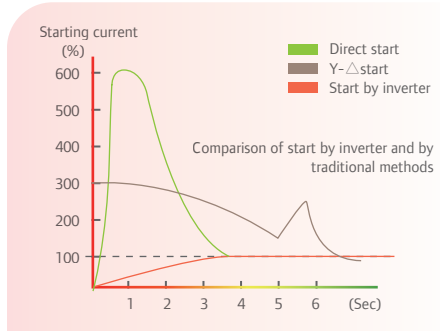

• High Efficiency Oil Balance and Oil Return Technology

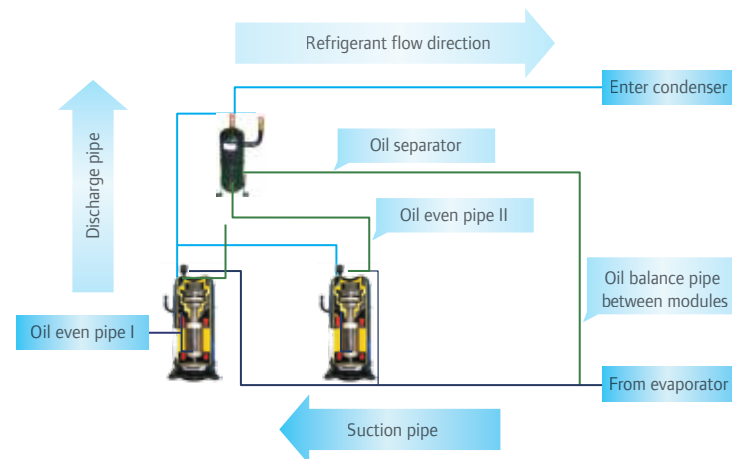

High efficiency centrifugal oil separator (up to 99%) separates oil from discharge and goes back to compressor.

Auto-oil-return ensures reliable oil return by monitoring the running time and state of the system.

• High Performance Heat Exchanger

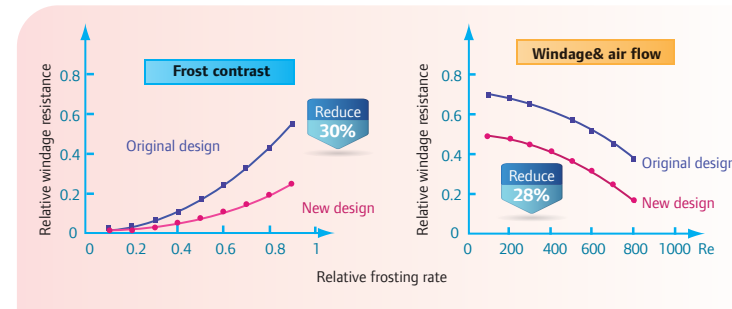
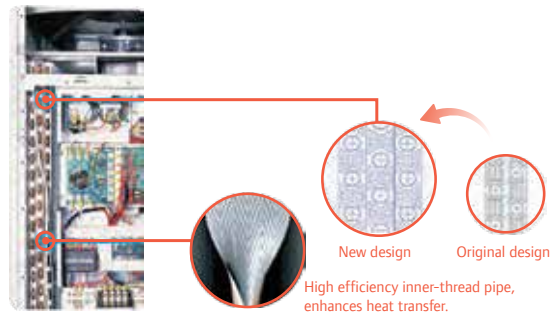

• Intelligent Defrost Improves the Heat Capacity

Intelligent Defrost increases the heating time in the cycle by implementing rapid defrost.

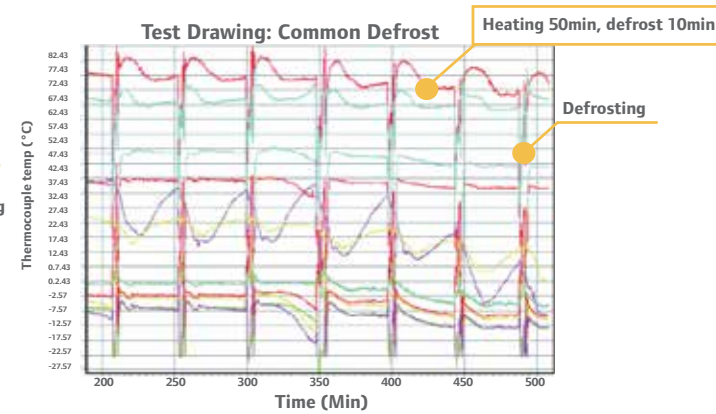

Absolute Comfort

Comfort and convenience in your hands

• Night Silent Operation

Night Silent Operation Mode can be easily set on the PCB (Printed Circuit Board) which optimizes the noise output by allowing different time settings during peak and non-peak operation time.

Extra silent operation mode can reduce sound level further, min. 46.8B (A).

Extra silent operation mode will be activated X hours after the unit reaches peak temperature during daytime, and it will go back to normal operation after Y hours.

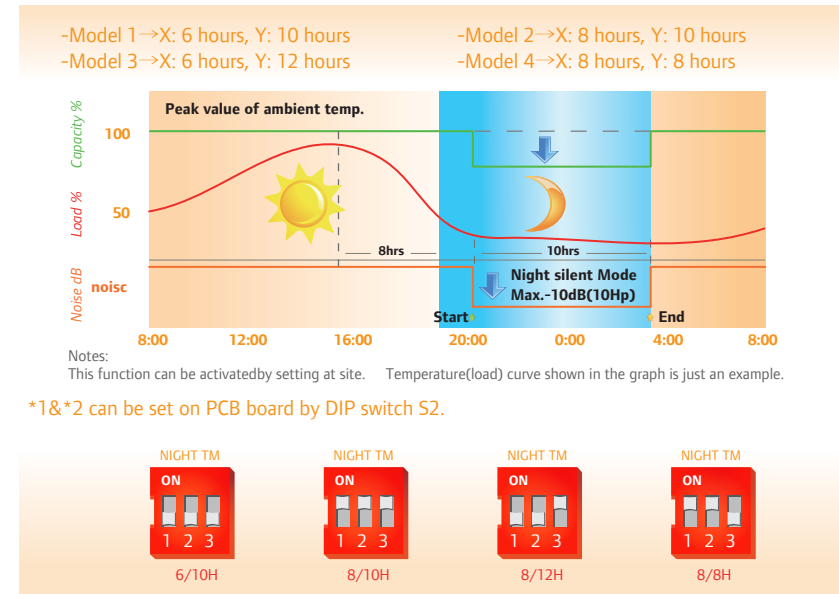

• Low Noise Level

The integration of DC inverter technology results in one of the industry's lowest noise levels, 21dB(A) for indoor units, which is equivalent to a whisper 1.5m away; and 47dB(A) for outdoor units, which is lower than the requirement for a quiet office room.

• Quick Heating & Cooling Design

Thanks to the features of scroll compressor, TVR™ II system can reach full load quickly and shorten heating or cooling time significantly.

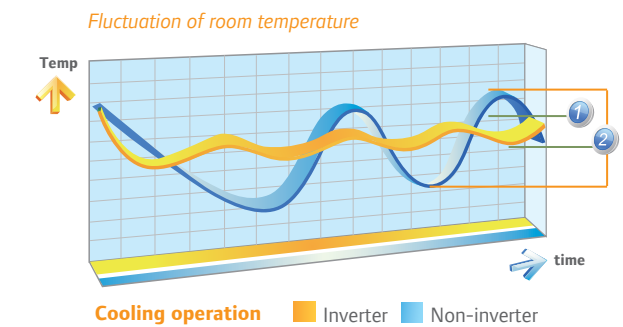

• Accurate Temperature/Humidity Control

With advanced control technology, TVR™ II system can accurately control the room temp. within a narrow temp. band thus avoiding energy wastage and creating the most comfortable environment. The set point will be stable at +/- 0.5°C.

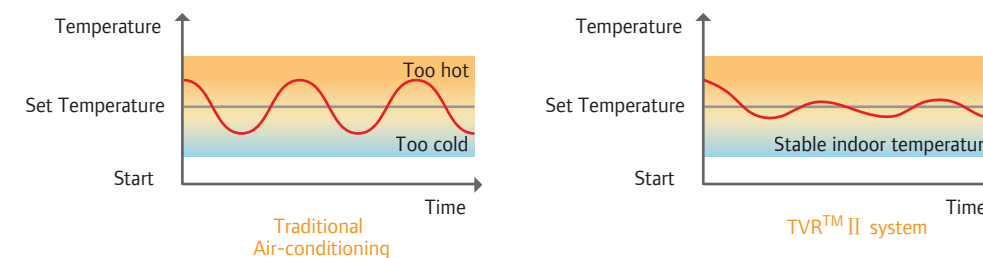

Sheer Reliability

Each unit is rigorously tested before shipment

- **Outdoor Module Back Up Operation**

Any single unit can be set as the master unit in a multiple system when the previous master unit failed and other units left will keep on operating. This can be set on PCB by DIP switches at site.



- **Alternate Cycle Duty Operation of Outdoor Units**

In one combination, any of the outdoor unit can run as the master outdoor unit, to realize the equal lifespan among the outdoor units in the combination.



- **Wide Operation Range**

No matter if it is tremendously cold winter, when outdoor temperature dips to as low as -15°C , or a hot summer, when temperature rises up to 48°C , the TVR™ II system operates in stable condition.

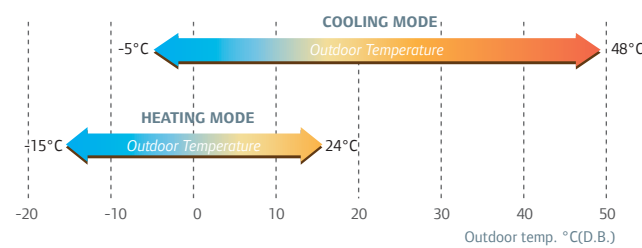

Easy Installation and Maintenance

Less space yet more value

- **Slim and Elegant Design**

Its compact size and lightweight design requires small installation footprint and installation floor load. Since it's easy to ship, some units can be shipped in general size elevators or via fork-lifts, reducing access issues at the job site.

- **Time Saving and Cost Effective Solution for Retrofit Projects**

TVR™ II is designed to provide not only superior comfort but also easy installation. With newly developed dynamic gas balance and high efficiency oil balance technology together with auto addressing, TVR™ II is a solution for various applications, even for retrofitting VRF projects. This eventually saves installation time and cost considerably.

- **Simple Signal Line Connection**

It is easy to install, as the communication wiring between indoor and outdoor units can be shared. Similarly, for retrofit projects, it's easy to upgrade the existing system with a centralized system just by simply connecting to the outdoor units.

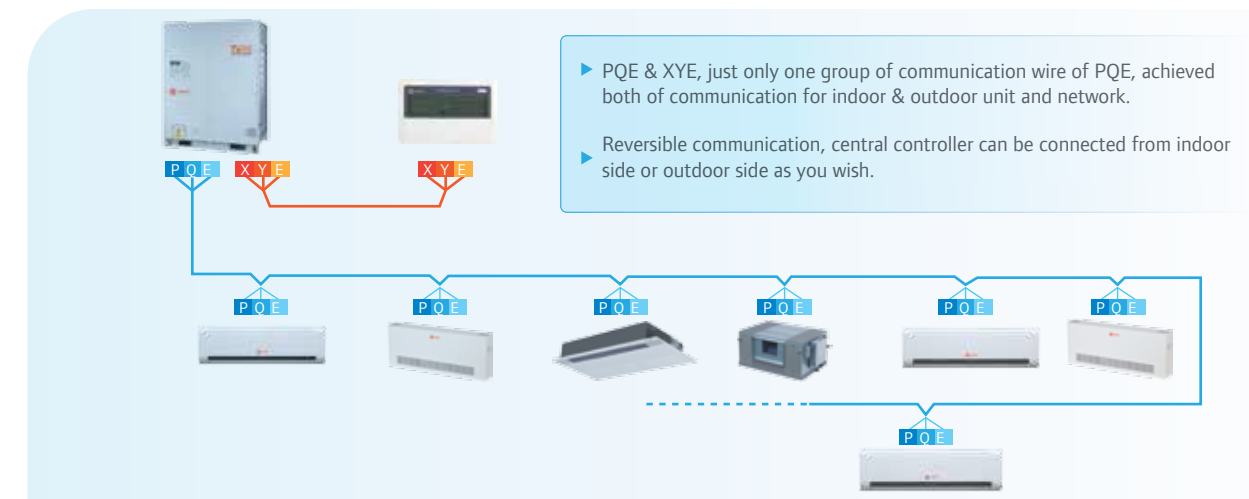

- **Remote Addressing**

Addressing indoor units can be done simply by pressing the button on the controller while there is no need to set the address by the DIP switch one by one.

Wired and wireless controller can enquire and modify every indoor unit address.

Up to 64 indoor units can be connected to one system.

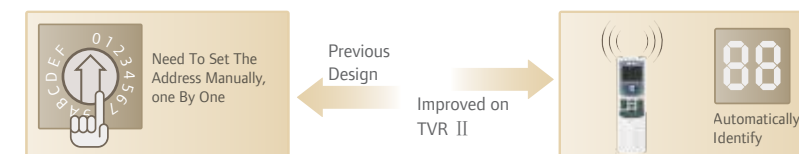

- **Easy Access**

Reserved checking window on electrical control box helps to have spot checking and status enquiry.

Compressors locate closely with the door, which is convenient for checking or replacing the valves or any other part.



Flexible design

Convenient administration

- **Large Capacity**

The outdoor units' capacity ranges from 8HP up to 80HP in 2HP increment. Maximum 64 indoor units with capacity up to 130% of total outdoor units can be connected as one refrigeration system. Thus, it's applicable to different types of applications, large or small.

- **Long Piping**

			Permitted value
Piping length	Total pipe length*(Actual)	≤30HP	350m
		>30HP	500m
	Maximum piping (L)	Actual length	150m
		Equivalent length	175m
Drop height	Piping (farthest from the first line pipe branch) equivalent length		40m
	Indoor unit - outdoor unit drop height	Outdoor unit up	70m*
		Outdoor unit down	70m
	Indoor unit to indoor unit drop height		15m

*Total pipe length is equal to gas pipe or liquid pipe length.

*Level difference above 50m are not supported by default but are available on request for customized.

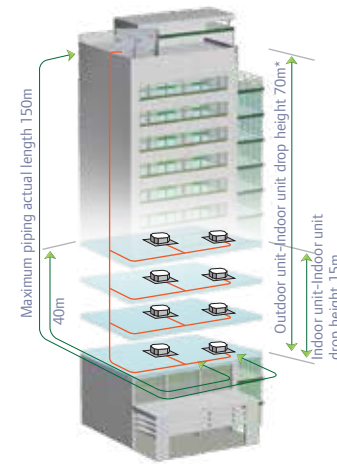

- **Individual Comfort**

TVR™ II system allows customization where zones can be easily added, changed or deleted depending on the changing needs of users or tenants.

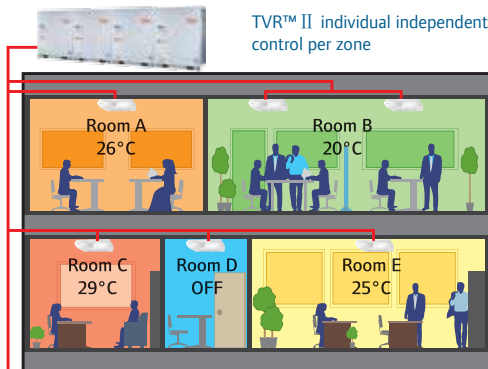

- **Extra High Static Pressure for Limited Height Application - Max. 81.8Pa with Air Volume Increased by 10%**

In order to adapt to various installation environments, high static environment pressure propeller and optimum fan guard are used. Trane offers up to 81.8Pa external static pressure units as an option for limited height installation, while a standard 0-20Pa function is equipped as default.

- **Multiple Modules Design for More Applicable Options**

Hotel insert card module makes things easier for hotel application. Ammeter could be your close assistant for electricity bill calculation.

- **Maximum Indoor Unit Quantity**

Outdoor unit combination

HP	Mode	Max Indoor Units nos.	HP	Mode	Max Indoor Units nos.	HP	Mode	Max Indoor Units nos.	HP	Mode	Max Indoor Units nos.
8	8HPx1	13	28	12HP + 16HP	40	46	12HP + 14HP + 20HP	64	64	12HPx2 + 20HPx2	64
10	10HPx1	16	30	12HP + 18HP	43	48	12HP + 16HP + 20HP	64	66	12HP + 14HP + 20HPx2	64
12	12HPx1	17	32	12HP + 20HP	46	50	12HP + 18HP + 20HP	64	68	12HP + 16HP + 20HPx2	64
14	14HPx1	20	34	20HP + 14HP	49	52	12HP + 20HPx2	64	70	12HP + 18HP + 20HPx2	64
16	16HPx1	23	36	20HP + 16HP	52	54	14HP + 20HPx2	64	72	12HP + 20HPx3	64
18	18HPx1	26	38	20HP + 18HP	55	56	16HP + 20HPx2	64	74	14HP + 20HPx3	64
20	20HPx1	29	40	20HPx2	58	58	18HP + 20HPx2	64	76	16HP + 20HPx3	64
22	10HP + 12HP	33	42	10HP + 12HP + 20HP	62	60	20HPx3	64	78	18HP + 20HPx3	64
24	12HPx2	34	44	12HPx2 + 20HP	63	62	10HP + 12HP + 20HPx2	64	80	20HPx4	64
26	12HP + 14HP	37									

Excellent Service

Trane offerings are more than you ever expected

- **Extensive Service**

Service and maintenance agreements are tailored to your need, which means you pay only for what you need.

Certified service networks through dealers trained and monitored by Trane.

Online monitoring through network software integrated with OMS*

*Depending on system and controller selection.

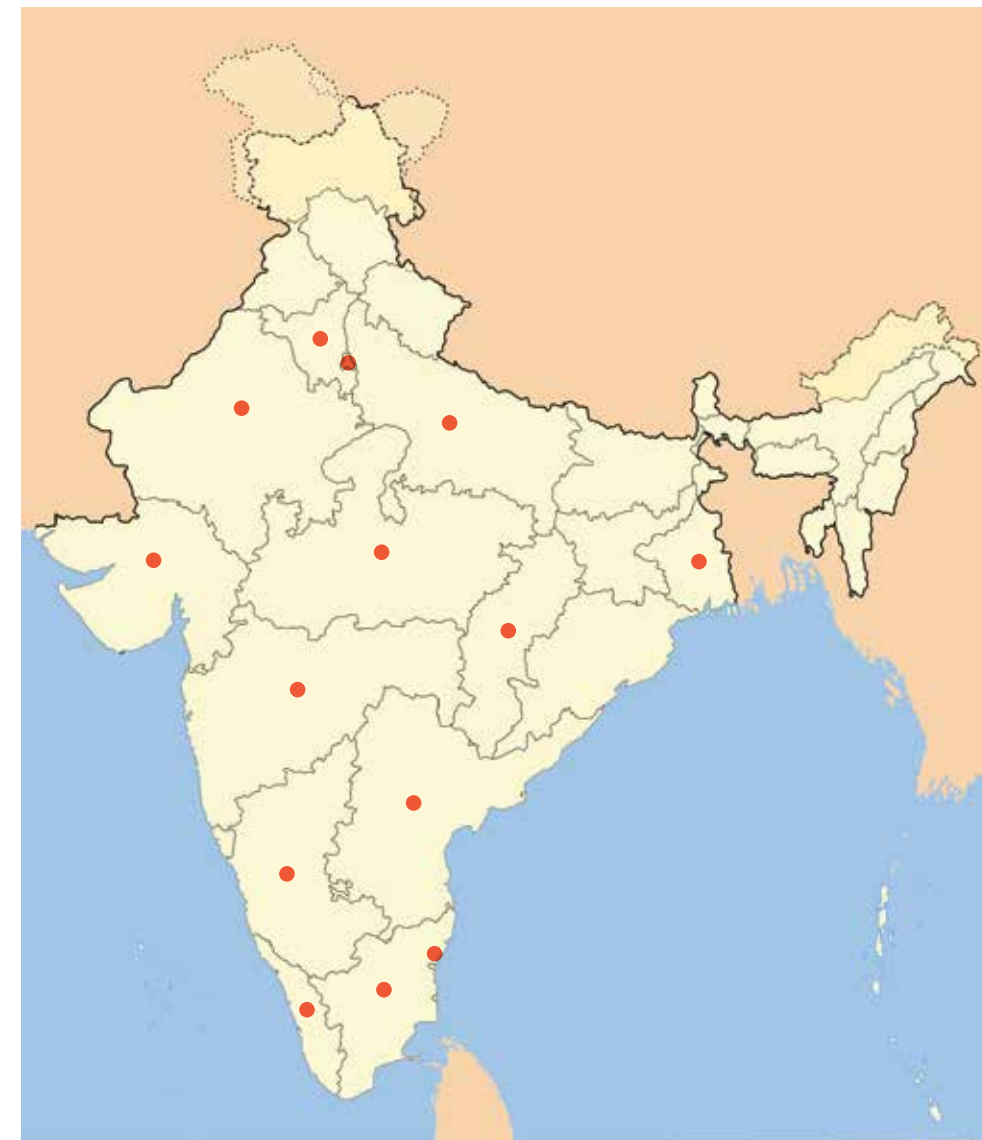

- **Selection Software Enabling Quick Selection and Verification**

User friendly, 5 steps only, large interface, colorful screen, all are tailored for your joyful experience.

All-in-one software: load calculation, unit's selection, piping selection, wiring connection guideline etc. You can easily generate the selection result with selected models, capacity of each indoor unit, and quotation.

Environmentally Responsible



Intelligent control system brings comfort and reduces energy consumption

Environment Friendly

As a global leader in indoor climate control systems, Trane considers it a responsibility to develop solutions that reduce energy consumption and soften environmental impact. TVR™ II system is one of the solutions that ideally reflect this concept as it operates with the highly efficient R410A refrigerant with zero ozone layer depleting potential. R410A provides increased system performance and heat transfer which results in reduced pipe sizes, reduced refrigerant quantity and saving on installation costs.

Outdoor Units



Outdoor Units

TVR™ II Mini - Residential Comfort

A very compact condensing unit that allows the TVR™ II Indoor unit range to be connected to a single outdoor unit.



Features

- 3 power levels 12, 14 and 16 kW (50 Hz)
- High Efficiency Heat Pump unit with R410A
- DC inverter fan motor

Compact

- Maximum economy of space, one 16kW outdoor unit controls up to maximum 7 indoor units
- Can be installed close to a wall

Low Noise

- Very low noise level on the outdoor unit, 57 dB(A) at 1 meter from the unit
- Low starting current because of the DC inverter technology

Flexibility

- Easy to install, fits inside an elevator, no need for a crane
- Long piping length for spot cooling or heating, 70m equivalent piping and 30m height difference when OD unit is above

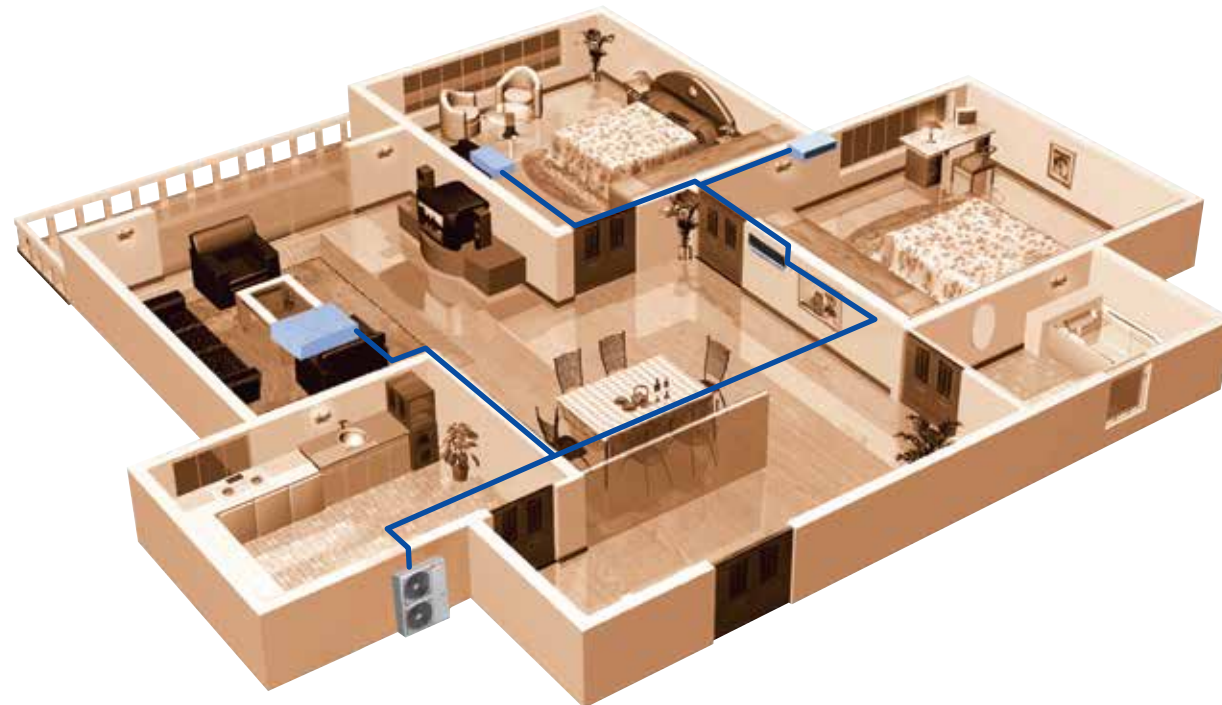

Mini TVR™ II Condensing Units - 50Hz

Model Name			4TVH0040BB	4TVH0048BB	4TVH0055BB	4TVH0040BD	4TVH0048BD	4TVH0055BD
Capacity	HP		4 HP	5 HP	6 HP	4 HP	5 HP	6 HP
Power supply	V-ph-Hz		220-240-1-50	220-240-1-50	220-240-1-50	380-415V 3Ph 50Hz	380-415V 3Ph 50Hz	380-415V 3Ph 50Hz
Cooling	Capacity	kW	12	14	15.5	12	14	15.5
		Btu/hr	40,900	47,800	52,900	40,900	47,800	52,900
	Power Input	W	3,250	3,950	4,520	3,250	3,950	4,520
	EER	W/W	3.69	3.54	3.43	3.69	3.54	3.43
Heating	Capacity	kW	13.2	15.4	17	13.2	15.4	17
		Btu/hr	45,000	52,500	58,000	45,000	52,500	58,000
	Power Input	W	3,470	4,160	4,770	3,470	4,160	4,770
	COP	W/W	3.80	3.70	3.56	3.80	3.70	3.56
Outdoor Air Flow	m3/h		6000	6000	6000	6000	6000	6000
Sound Level	dB(A)		57	57	57	57	57	57
Fin Type			Hydrophilic Aluminium			Hydrophilic Aluminium		
Outdoor unit	Dimension (WxHxD)	mm	900x1327x320	900x1327x320	900x1327x320	900x1327x320	900x1327x320	900x1327x320
	Packing (WxHxD)	mm	1030x1456x435	1030x1456x435	1030x1456x435	1030x1456x435	1030x1456x435	1030x1456x435
	Net/Gross weight	Kg	95/106	95/106	100/111	95/106	95/106	100/111
Charged refrigerant type and amount	Kg		R410A 3.3kg	R410A 3.9kg	R410A 3.9kg	R410A 3.3kg	R410A 3.9kg	R410A 3.9kg
Refrigerant Piping	Liquid side/ Gas side	mm	Φ9.52/Φ15.9	Φ9.52/Φ15.9	Φ9.52/Φ19.1	Φ9.52/Φ15.9	Φ9.52/Φ15.9	Φ9.52/Φ19.1
	Total pipe length	m	100	100	100	100	100	100
	Max Equivalent Pipe Length	m	70	70	70	70	70	70
	Max Level between ID's	m	8	8	8	8	8	8
	Max Level between OD & ID	m	30	30	30	30	30	30
Max. Amount of IUs connected to OU			6	6	7	6	6	7
Ambient temp. range - Cooling	°C		-15°C—48°C	-15°C—48°C	-15°C—48°C	-15°C—48°C	-15°C—48°C	-15°C—48°C
Ambient temp. range - Heating	°C		-15°C—27°C	-15°C—27°C	-15°C—27°C	-15°C—27°C	-15°C—27°C	-15°C—27°C

* Nominal cooling capacities are based on the following conditions: return air temperature: 27 CDB, 19 CWB, outdoor temperature: 35 CDB, equivalent ref. piping: 7.5 m (horizontal)
 * Nominal heating capacities are based on the following conditions: return air temperature: 20 CDB, 15 CWB, outdoor temperature: 7 CDB, 6 CWB, equivalent ref. piping: 7.5 m (horizontal)
 * Sound level: Anechoic chamber conversion value, measured at a position 1m in front of the unit and 1.5 m above the floor.
 * Refrigerant pipe dim. Listed here only for the total equivalent length < 90m. For the data when total equivalent length ≥ 90m, please refer to technical manual.
 * The above data may be changed without notice for further improvement on quality and performance.



TVR™ II Heat Pump Outdoor Units

- 4 different modules can work together in a master-slave configuration
- Any outdoor unit module in a group can be the designated master or slave
- All TVR II outdoor units have the same height and depth allowing for row installation
- Linear Capacity control
- Continuous cooling under high ambient condition up to 48°C
- No mechanical rooms needed, fits in elevator



Comfort

- Auto restart function, no need for re-programming
- Low noise design
- Back up function

Service

- Easy maintenance with the self-diagnostic function and test switch
- Flexible start up procedure and automated piping / wiring checks
- Self-addressing of indoor units
- Optional service software

Optional Accessories

- TVR™ II Outdoor unit centralized controller
- Digital Ampere Meter



Sound Pressure at 1m

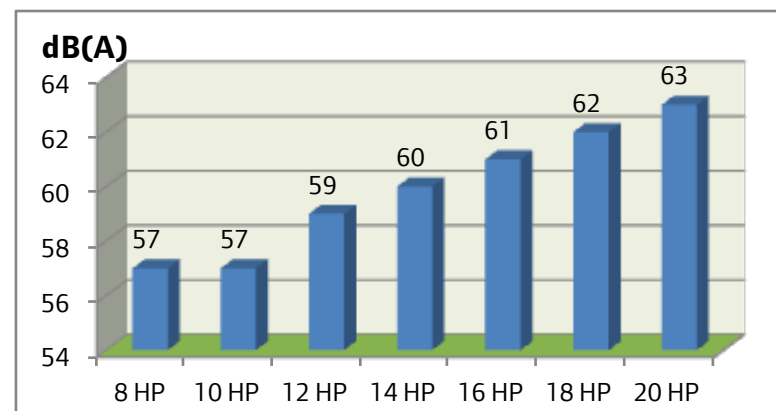

TVR™ II Condensing Units - 50Hz Specifications:

Model Name		4TVH0086CD	4TVH0096CD	4TVH0115CD	4TVH0140CD	4TVH0155CD	4TVH0171CD	4TVH0191CD
Capacity	HP	8 HP	10 HP	12 HP	14 HP	16 HP	18 HP	20 HP
Power supply	V-ph-Hz	380-415V 3Ph 50Hz	380-415V 3Ph 50Hz	380-415V 3Ph 50Hz	380-415V 3Ph 50Hz	380-415V 3Ph 50Hz	380-415V 3Ph 50Hz	380-415V 3Ph 50Hz
Cooling	Capacity	kW	25.2	28	33.5	40	45	50
		Btu/hr	86,000	95,500	1,14,300	1,36,500	1,53,500	1,70,600
	Power Input	W	5,940	7,390	9,410	12,460	14,060	15,770
	EER	W/W	4.24	3.79	3.56	3.21	3.20	3.17
Heating	Capacity	kW	27	31.5	37.5	45	50	56
		Btu/hr	92,100	1,07,500	1,28,000	1,53,500	1,70,600	1,91,100
	Power Input	W	6,210	7,660	9,260	11,280	12,890	14,550
	COP	W/W	4.35	4.11	4.05	3.99	3.88	3.85
Outdoor Air Flow	m ³ /h	11500	11500	11500	15100	15100	15100	15250
Sound Level	dB(A)	57	57	59	60	61	62	63
Fin Type		Hydrophilic Aluminium						
Outdoor unit	Dimension (WxHxD)	mm	960x1615x765	960x1615x765	960x1615x765	1250x1615x765	1250x1615x765	1250x1615x765
	Packing (WxHxD)	mm	1025x1790x830	1025x1790x830	1025x1790x830	1305x1790x825	1305x1790x825	1305x1790x825
	Net/Gross weight	Kg	198/213	198/213	198/213	268/288	280/300	280/300
Charged refrigerant type and amount	Kg	R410A 9kg	R410A 9kg	R410A 9kg	R410A 11kg	R410A 13kg	R410A 13kg	R410A 13kg
Refrigerant Piping	Liquid side/ Gas side	mm	Φ12.7/Φ22.2	Φ12.7/Φ25.4	Φ15.9/Φ28.6	Φ15.9/Φ28.6	Φ15.9/Φ31.8	Φ19.1/Φ31.8
	Oil balance pipe	mm	Φ6.35	Φ6.35	Φ6.35	Φ6.35	Φ6.35	Φ6.35
	Total pipe length	m	500	500	500	500	500	500
	Max Equivalent Pipe Length	m	175	175	175	175	175	175
	Max Level between ID's	m	15	15	15	15	15	15
Max Level between OD & ID	m	70	70	70	70	70	70	
Max. Amount of IUs connected to OU		13	16	17	20	23	26	29
Ambient temp. range - Cooling	°C	-5°C—48°C	-5°C—48°C	-5°C—48°C	-5°C—48°C	-5°C—48°C	-5°C—48°C	-5°C—48°C
Ambient temp. range - Heating	°C	-20°C—27°C	-20°C—27°C	-20°C—27°C	-20°C—27°C	-20°C—27°C	-20°C—27°C	-20°C—27°C

* Nominal cooling capacities are based on the following conditions: return air temperature: 27 CDB, 19 CWB, outdoor temperature: 35 CDB, equivalent ref. piping: 7.5 m (horizontal)

* Nominal heating capacities are based on the following conditions: return air temperature: 20 CDB, outdoor temperature: 7 CDB, 6 CWB, equivalent ref. piping: 7.5 m (horizontal)

* Capacities are net, not including a deduction for cooling (an addition for heating) for indoor fan motor heat

* The operating sound has been measured in a semi anechoic chamber. The microphone was located 1m in front of the unit.

With actual installation, the indication value normally differs widely according to the surrounding noise and reverberations.

Note: Specifications subject to change without notice.



Table of Outdoor Unit combinations:

Combined ODU Capacity		Recommend Combination						Max Indoor Units nos.	
		8 HP	10 HP	12 HP	14 HP	16 HP	18 HP		20 HP
		25.2 KW	28 KW	33.5 KW	40 KW	45 KW	50 KW		56 KW
8 HP	25.2 KW	0							13
10 HP	28 KW		0						16
12 HP	33.5 KW			0					17
14 HP	40 KW				0				20
16 HP	45 KW					0			23
18 HP	50 KW						0		26
20 HP	56 KW							0	29
22 HP	61.5 KW		0	0					33
24 HP	67 KW			00					34
26 HP	73.5 KW			0	0				37
28 HP	78.5 KW			0		0			40
30 HP	83.5 KW			0			0		43
32 HP	89.5 KW			0				0	46
34 HP	96 KW				0			0	49
36 HP	101 KW					0		0	52
38 HP	106 KW						0	0	55
40 HP	112 KW							00	58
42 HP	117.5 KW		0	0				0	62
44 HP	123 KW			00				0	63
46 HP	129.5 KW			0	0			0	64
48 HP	134.5 KW			0		0		0	64
50 HP	139.5 KW			0			0	0	64
52 HP	145.5 KW			0				00	64
54 HP	152 KW				0			00	64
56 HP	157 KW					0		00	64
58 HP	162 KW						0	00	64
60 HP	168 KW							000	64
62 HP	173.5 KW		0	0				00	64
64 HP	179 KW			00				00	64
66 HP	185.5 KW			0	0			00	64
68 HP	190.5 KW			0		0		00	64
70 HP	195.5 KW			0			0	00	64
72 HP	201.5 KW			0				000	64
74 HP	208 KW				0			000	64
76 HP	213 KW					0		000	64
78 HP	218 KW						0	000	64
80 HP	224 KW							0000	64

Indoor Units



Indoor One Way Cassette Unit Series



• Slim and Compact

Compact design, ultra slim body with a minimum thickness of only 198mm, especially suitable for places with narrow ceilings, such as lobby, small sized meeting room etc.

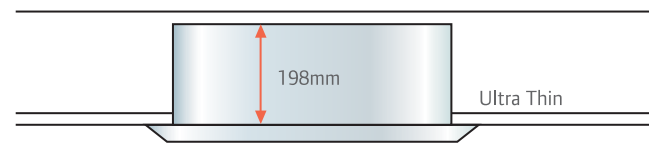

Standard built-in drain pump with 750mm head and slim body, which removes the limitation of storey height during installation.



Auto swing mechanism, ensures even distribution of airflow and a better balance in room temperature.

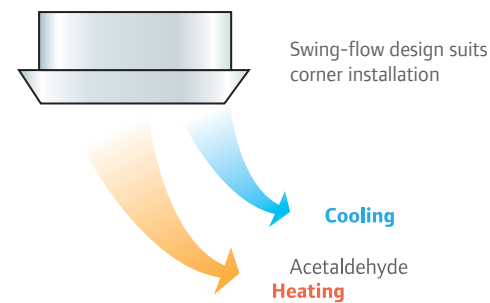

• High Air Flow

High air flow for high ceiling application ensures even air distribution to every corner of the room, thereby providing optimum comfort.

• Fresh Air with Improved Air Quality

Reserved fresh air intake, as required for high quality air supply, creates a comfortable and healthy environment.

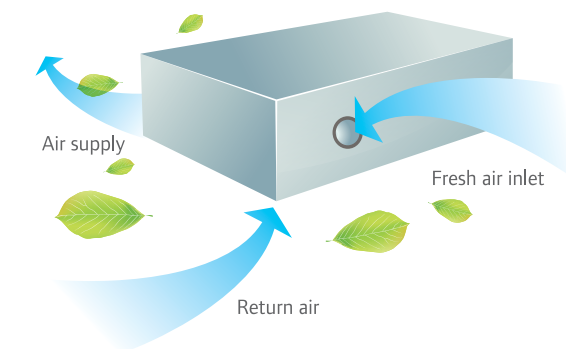

Special enzyme sterilization and filtering technology filters the bacteria, smog, pollen etc. and gives clean and healthy air.

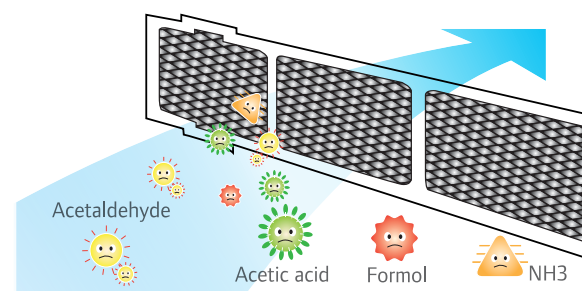

• Specifications

Model Name			4TVE0009BB	4TVE0012BB	4TVE0015BB	4TVE0018BB
Power supply		V-ph-Hz	220-240-1-50	220-240-1-50	220-240-1-50	220-240-1-50
Capacity	Cooling	kW	2.8	3.6	4.5	5.6
		Btu/hr	9,600	12,300	15,400	19,100
	Heating	kW	3.2	4	5	6.3
		Btu/hr	10,900	13,600	17,100	21,500
Rated Power		W	53	53	86	86
Rated Current		A	0.3	0.3	0.4	0.41
Air Flow (H/ M/ L)		m ³ /h	500/450/410	500/450/410	894/800/750	894/800/750
Sound Level (H/ M/ L)		dB(A)	36/34/30	36/34/30	41/38/35	41/38/35
Indoor unit	Dimension (WxHxD)	mm	850×235×400	850×235×400	1200×198×655	1200×198×655
	Packing (WxHxD)	mm	1080×320×460	1080×320×460	1380×265×775	1380×265×775
	Net/Gross weight	Kg	23/27	23/27	31/38	31/38
Panel	Dimension (WxHxD)	mm	1050×18×470	1050×18×470	1420×10×755	1420×10×755
	Packing (WxHxD)	mm	1100×40×520	1100×40×520	1470×50×805	1470×50×805
	Net/Gross weight	Kg	4/6	4/6	9/11	9/11
Refrigerant piping	Liquid side/ Gas side	mm	Φ6.35/ Φ12.7	Φ6.35/ Φ12.7	Φ6.35/ Φ12.7	Φ9.52/ Φ15.9
Drainage Water Pipe Outer Diameter		mm	ODΦ16	ODΦ16	ODΦ16	ODΦ16

Note:

- Nominal cooling capacities are based on the following conditions: return air temp.: 27 °C DB, 19 °C WB, outdoor temp.: 35 °C DB, equivalent ref. Piping: 7.5m (horizontal)
- Nominal heating capacities are based on the following conditions: return air temp.: 20 °C DB, outdoor temp.: 7 °C DB, 6 °C WB, equivalent ref. Piping: 7.5m (horizontal)
- Sound level is measured 1m below the unit

Indoor Two Way Cassette Unit Series



• Slim and Compact

Compact design, ultra slim body with a minimum thickness of only 300mm, especially suitable for places with narrow ceilings, such as lobby, small sized meeting room etc.

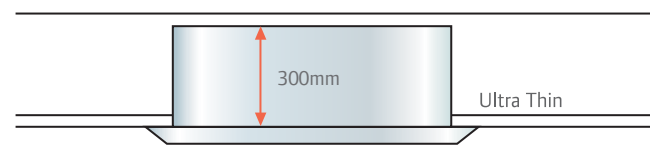

Standard built-in drain pump with 750mm head and slim body, which removes the limitation of storey height during installation.



Auto swing mechanism, ensures even distribution of airflow and a better balance in room temperature.

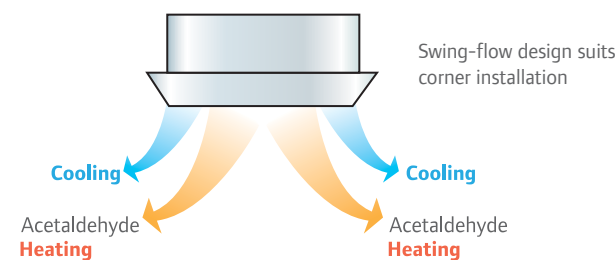

• High Air Flow

High air flow for high ceiling application ensures even air distribution to every corner of the room, thereby providing optimum comfort.

• Comfort

- Low sound level (24 dB (A))
- Efficient air distribution
- Built-in Auto-restart
- Standard filter

• Specifications

Model Name		4TVG0007BB	4TVG0009BB	4TVG0012BB	4TVG0015BB	4TVG0018BB	4TVG0024BB	
Power supply	V-ph-Hz	220-240-1-50	220-240-1-50	220-240-1-50	220-240-1-50	220-240-1-50	220-240-1-50	
Capacity	Cooling	kW	2.2	2.8	3.6	4.5	5.6	7.1
		Btu/hr	7,500	9,600	12,300	15,400	19,100	24,200
	Heating	kW	2.6	3.2	4	5	6.3	8
		Btu/hr	8,900	10,900	13,600	17,100	21,500	27,300
Rated Power	W	57	57	60	92	108	154	
Rated Current	A	0.35	0.45	0.45	0.55	0.55	0.75	
Air Flow (H/ M/ L)	m3/h	654/530/410	654/530/410	725/591/458	850/670/550	980/800/670	1200/1000/770	
Sound Level (H/ M/ L)	dB(A)	33/29/24	36/32/29	36/32/29	39/35/30	39/35/30	44/40/34	
Indoor unit	Dimension (WxHxD)	mm	1172×300×592	1172×300×592	1172×300×592	1172×300×592	1172×300×592	
	Packing (WxHxD)	mm	1355×400×675	1355×400×675	1355×400×675	1355×400×675	1355×400×675	
	Net/Gross weight	Kg	34/42.5	34/42.5	34/42.5	36.5/45	36.5/45	36.5/45
Panel	Dimension (WxHxD)	mm	1430×90×680	1430×90×680	1430×90×680	1430×90×680	1430×90×680	
	Packing (WxHxD)	mm	1525×130×765	1525×130×765	1525×130×765	1525×130×765	1525×130×765	
	Net/Gross weight	Kg	10.5/15	10.5/15	10.5/15	10.5/15	10.5/15	10.5/15
Refrigerant piping	Liquid side/ Gas side	mm	Φ6.35/ Φ12.7	Φ6.35/ Φ12.7	Φ6.35/ Φ12.7	Φ6.35/ Φ12.7	Φ9.53/ Φ15.9	
Drainage Water Pipe Outer Diameter	mm	ODΦ32	ODΦ32	ODΦ32	ODΦ32	ODΦ32	ODΦ32	

Note:

1. Nominal cooling capacities are based on the following conditions: return air temp.: 27°C DB, 19°C WB, outdoor temp.: 35°C DB, equivalent ref. Piping: 7.5m (horizontal)
2. Nominal heating capacities are based on the following conditions: return air temp.: 20°C DB, outdoor temp.: 7°C DB, 6°C WB, equivalent ref. Piping: 7.5m (horizontal)
3. Sound level is measured 1m below the unit

Indoor Compact Four Way Cassette Unit Series



• Compact Design, Easy Installation and Maintenance

Extremely compact casing makes it a perfect match to the ambient decoration. Little space is required for installation into a shallow ceiling. You can install all models without a hoist by virtue of its compact body and light weight.

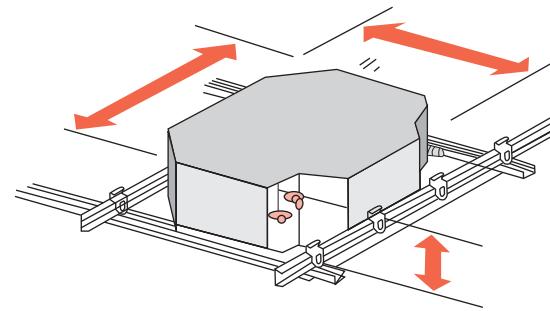

• Quiet Operation and Soft Air Supply

It operates quietly through streamline plate. And its advanced 3-D spiral fan design offers lower air resistance and less operation noise.

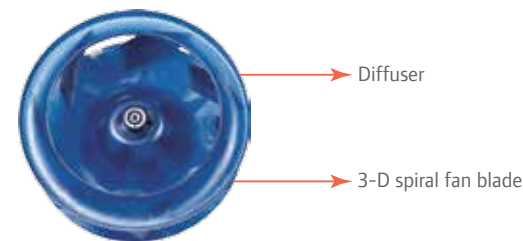

• Uniform Air Flow of Four Ways

The Four-way air discharge ports provide strong circulation of air flow to cool/heat every corner of the room so that there is even temperature distribution. It gives equal comfort for high ceiling application over 3m under high airflow mode.



• 360° Air Flow Outlet

360° air outlet provides strong circulation of air flow to cool/heat throughout every corner of the room.



Drain up pump with 500mm pump head is fitted as standard, with 600mm head as the maximum.

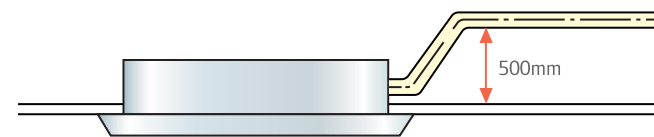

• Specifications

Model Name			4TVB0007BB	4TVB0009BB	4TVB0012BB	4TVB0015BB
Power supply		V-ph-Hz	220-240-1-50	220-240-1-50	220-240-1-50	220-240-1-50
Capacity	Cooling	kW	2.2	2.8	3.6	4.5
		Btu/hr	7,500	9,600	12,300	15,400
	Heating	kW	2.4	3.2	4	5
		Btu/hr	8,200	10,900	13,600	17,100
Rated Power		W	48	48	56	56
Rated Current		A	0.22	0.22	0.25	0.25
Air Flow (H/ M/ L)		m ³ /h	522/414/313	522/414/313	610/521/409	610/521/409
Sound Level (H/ M/ L)		dB(A)	35.8/33.4/23.4	35.8/33.4/23.4	41.5/35.6/28.8	41.5/35.6/28.8
Indoor unit	Dimension (WxHxD)	mm	570x260x570	570x260x570	570x260x570	570x260x570
	Packing (WxHxD)	mm	675x285x675	675x285x675	675x285x675	675x285x675
	Net/Gross weight	Kg	17.5/22	17.5/22	19/23.5	19/23.5
Panel	Dimension (WxHxD)	mm	648x50x648	648x50x648	648x50x648	648x50x648
	Packing (WxHxD)	mm	715x123x715	715x123x715	715x123x715	715x123x715
	Net/Gross weight	Kg	2.5/4.5	2.5/4.5	2.5/4.5	2.5/4.5
Refrigerant piping	Liquid side/ Gas side	mm	Φ6.35/Φ12.7	6.35/12.7	6.35/12.7	6.35/12.7
Drainage Water Pipe Outer Diameter		mm	ODΦ25	ODΦ25	ODΦ25	ODΦ25

Note:

- Nominal cooling capacities are based on the following conditions: return air temp.: 27 °C DB, 19 °C WB, outdoor temp.: 35 °C DB, equivalent ref. Piping: 7.5m (horizontal)
- Nominal heating capacities are based on the following conditions: return air temp.: 20 °C DB, outdoor temp.: 7 °C DB, 6 °C WB, equivalent ref. Piping: 7.5m (horizontal)
- Sound level is measured 1.4m below the unit

Indoor Four Way Cassette Unit Series



• Uniform Air Flow of Four Ways

The Four air discharge ports provide strong circulation of air flow to cool/heat throughout every corner of the room so that there is even temperature distribution. It gives equal comfort for high ceiling application over 3m under high airflow mode.

• Easy troubleshooting

By adding digital tube on the display board, the ERROR CODES can be spotted directly which helps find the problem and troubleshoot.



• High Lift Pump

Drain pump can take up the condenser water to 750mm which helps to make installation of drain piping system easier.

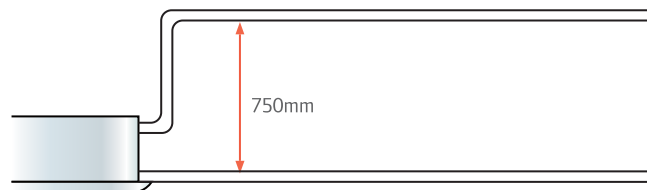

Ultra-thin machine body for easy installation and maintenance, min. 230mm in height

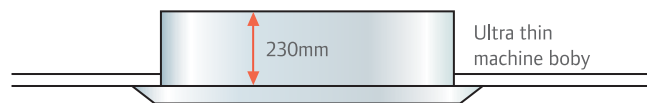

• Quiet Operation and Soft Air Supply

It operates quietly through streamline plate. And its advanced 3-D spiral fan design offers lower air resistance and less operation noise.

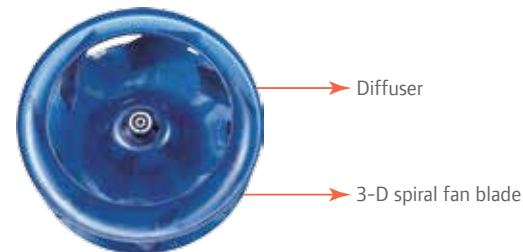

• Reserved Multi-Functional Ports

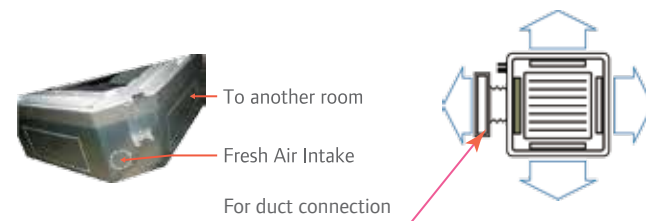

• Specifications

Model Name		4TVC0018BB	4TVC0024BB	4TVC0027BB	4TVC0030BB	4TVC0034BB	4TVC0038BB	4TVC0048BB	
Power supply	V-ph-Hz	220-240-1-50	220-240-1-50	220-240-1-50	220-240-1-50	220-240-1-50	220-240-1-50	220-240-1-50	
Capacity	Cooling	kW	5.6	7.1	8	9	10	11.2	14
		Btu/hr	19,100	24,200	27,300	30,700	34,100	38,200	47,800
	Heating	kW	6.3	8	9	10	11	12.5	15
		Btu/hr	21,500	27,300	30,700	34,100	37,500	42,700	51,200
Rated Power	W	75	82	97	160	160	160	170	
Rated Current	A	0.4	0.5	0.5	0.7	0.7	0.7	0.8	
Air Flow (H/ M/ L)	m3/h	864/755/658	1157/955/749	1236/973/729	1540/1300/1120	1540/1300/1120	1540/1300/1120	1800/1500/1280	
Sound Level (H/ M/ L)	dB(A)	42/38/35	45/42/39	45/42/39	48/45/43	48/45/43	48/45/43	50/47/44	
Indoor unit	Dimension (WxHxD)	mm	840x230x840	840x230x840	840x230x840	840x300x840	840x300x840	840x300x840	840x300x840
	Packing (WxHxD)	mm	955X247X955	955X247X955	955X247X955	955x317x955	955x317x955	955x317x955	955x317x955
	Net/Gross weight	Kg	26/30	26/30	26/30	32/37	32/37	32/37	32/37
Panel	Dimension (WxHxD)	mm	950x46x950	950x46x950	950x46x950	950x46x950	950x46x950	950x46x950	950x46x950
	Packing (WxHxD)	mm	1000x60x1000	1000x60x1000	1000x60x1000	1000x60x1000	1000x60x1000	1000x60x1000	1000x60x1000
	Net/Gross weight	Kg	6/8	6/8	6/8	6/8	6/8	6/8	6/8
Refrigerant piping	Liquid side/ Gas side	mm	Φ9.53/Φ15.9	Φ9.53/Φ15.9	Φ9.53/Φ15.9	Φ9.53/Φ15.9	Φ9.53/Φ15.9	Φ9.53/Φ15.9	
Drainage Water Pipe Outer Diameter	mm	ODΦ32	ODΦ32	ODΦ32	ODΦ32	ODΦ32	ODΦ32	ODΦ32	

Note:

1. Nominal cooling capacities are based on the following conditions: return air temp.: 27 °C DB, 19 °C WB, outdoor temp.: 35 °C DB, equivalent ref. Piping: 7.5m (horizontal)
2. Nominal heating capacities are based on the following conditions: return air temp.: 20 °C DB, outdoor temp.: 7 °C DB, 6 °C WB, equivalent ref. Piping: 7.5m (horizontal)
3. Sound level is measured 1.4m below the unit

Indoor Low Static Pressure Concealed Unit Series



• Wide Capacity Range

The capacity ranges from 6kBtu to 19kBtu which includes 6 models in total.



• Low Noise Level

The cross blow fan, operates on the lowest noise [21 dB (A)]. It is an excellent choice for hotels and other sound sensitive premises.



• More Smooth Air Flow with Less Turbulence

The multiple-blade fan rotor and air guide design leads to smooth air flow and higher comfort due to less turbulence.

• Convenient installation

The EXV is fixed beside the indoor unit. Suction chamber fitted as standard.

• Slim, light and compact design

With 190mm height, the compact design ensures easy location even in places where space over the ceiling is limited. With the min. weight only as 11.5Kg, the whole body adapts into fireproof plastic material.

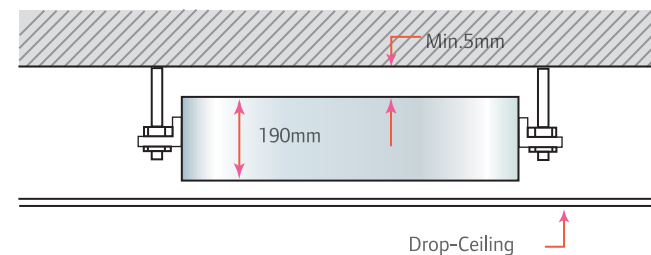

• More options

A drain-up pump is available as an optional accessory (750mm pump head).

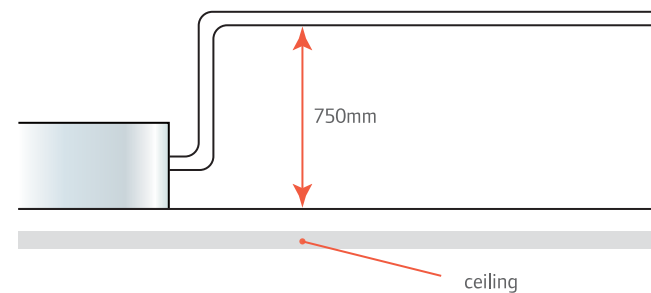

• Specifications

Model Name		4TVL0006BB	4TVL0007BB	4TVL0009BB	4TVL0012BB	4TVL0015BB	4TVL0018BB	
Power supply	V-ph-Hz	220-240-1-50	220-240-1-50	220-240-1-50	220-240-1-50	220-240-1-50	220-240-1-50	
Capacity	Cooling	kW	1.8	2.2	2.8	3.6	4.5	5.6
		Btu/hr	6,100	7,500	9,600	12,300	15,400	19,100
	Heating	kW	2.2	2.6	3.2	4	5	6.3
		Btu/hr	7,500	8,900	10,900	13,600	17,100	21,500
Rated Power	W	40	40	40	40	40	56	
Rated Current	A	0.17	0.17	0.17	0.17	0.17	0.24	
Air Flow (H/ M/ L)	m3/h	446/323/250	446/323/250	527/359/267	527/359/267	767/634/512	767/634/512	
Indoor External Static Pressure (H)	Pa	5	5	5	5	5	5	
Sound Level (H/ M/ L)	dB(A)	33/27/21	34/29/21	36/34/30	36/34/30	37/35/31	37/35/31	
Indoor unit	Dimension (WxHxD)	mm	850×190×405	850×190×405	850×190×405	850×190×405	1030×190×430	1030×190×430
	Packing (WxHxD)	mm	903×277×445	903×277×445	903×277×445	903×277×445	1084×277×472	1084×277×472
	Net/Gross weight	Kg	11.5/14.5	11.5/14.5	11.5/14.5	11.5/14.5	14 /17.5	14/17.5
Refrigerant piping	Liquid side/ Gas side	mm	Φ6.35/ Φ12.7	Φ6.35/ Φ12.7	Φ6.35/ Φ12.7	Φ6.35/ Φ12.7	Φ6.35/ Φ12.7	Φ9.53/ Φ15.9
Drainage Water Pipe Outer Diameter	mm	ODΦ20	ODΦ20	ODΦ20	ODΦ20	ODΦ20	ODΦ20	

Note:

- Nominal cooling capacities are based on the following conditions: return air temp.: 27 °C DB, 19 °C WB, outdoor temp.: 35 °C DB, equivalent ref. Piping: 7.5m (horizontal)
 - Nominal heating capacities are based on the following conditions: return air temp.: 20 °C DB, outdoor temp.: 7 °C DB, 6 °C WB, equivalent ref. Piping: 7.5m (horizontal)
 - Sound level is measured 1.4m below the air outlet
- * External static pressure are based on high speed indoor air flow
 * Specifications are subject to change without prior notice for product improvement

Indoor Medium Static Pressure Concealed Unit Series



• Wide Capacity Range

The capacity ranges from 7.5kBTu to 47.8kBTu including 10 models in total.

• Two External Static Pressure Settings for Added Flexibility

Four speed fan motor (Super high speed) is also available. The wiring connection of 'SH' and 'Hi' can be exchange to change the ESP.

• Easy Installation

EXV is fixed inside the indoor unit. Standard filter is placed in an aluminum frame, which can be removed downwards from the bottom. It has a standard suction chamber, fresh air-hole, air inlet/outlet flange for easy duct connection. Air inlet from the back is a standard and from bottom is optional with the same connectable duct.

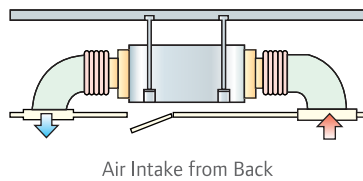

Air Intake from Back

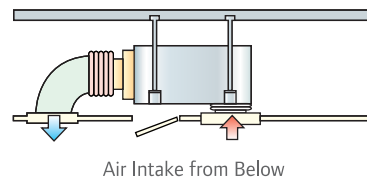

Air Intake from Below

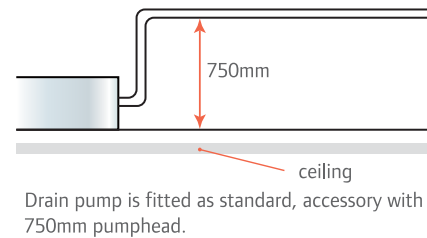

Drain pump is fitted as standard, accessory with 750mm pumphead.

• More Compact Body

With 210mm height, the EXV is built in the design of the indoor unit, No extra throttle kit box is attached with main body.

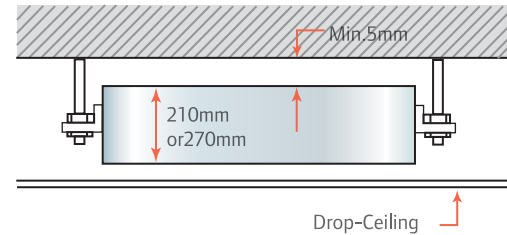

Drop-Ceiling

• Flexible Control and Convenient for Maintenance

Standard wired remote controller is available. The display board is connected with the E-box in factory, which enables easier troubleshooting by LED display. The electrical control box can be placed 1m away from the unit, ensuring maintenance within easy access. The EXV is screw connected, which provides more convenience for maintenance by way of unscrewing from the liquid pipe. The standard functional ports can be added to make it even more convenient such as Remote ON/OFF, dry contact switch and alarm signal output (220v).

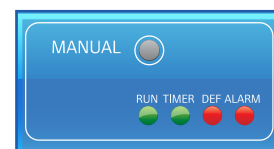

7-18 Model

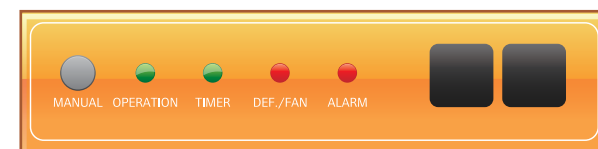

24-48 Model

• Specifications

Model Name			4TVD0007BB	4TVD0009BB	4TVD0012BB	4TVD0015BB	4TVD0018BB
Power supply		V-ph-Hz	220-240-1-50	220-240-1-50	220-240-1-50	220-240-1-50	220-240-1-50
Capacity	Cooling	kW	2.2	2.8	3.6	4.5	5.6
		Btu/hr	7,500	9,600	12,300	15,400	19,100
	Heating	kW	2.6	3.2	4	5	6.3
		Btu/hr	8,900	10,900	13,600	17,100	21,500
Rated Power		W	57	57	61	92	92
Rated Current		A	0.28	0.28	0.28	0.5	0.5
Air Flow (H/ M/ L)		m3/h	530/410/320	530/410/320	530/410/320	850/667/583	850/667/583
Indoor External Static Pressure (H)		Pa	10(10-30)	10(10-30)	10(10-30)	10(10-30)	10(10-30)
Sound Level (H/ M/ L)		dB(A)	38/35/32	38/35/32	40/38/36	41/38.9/36	41/38.9/36
Indoor unit	Dimension (WxHxD)	mm	790x210x635	790x210x635	790x210x635	1010x210x635	1010x210x635
	Packing (WxHxD)	mm	915x290x655	915x290x655	915x290x655	1135x290x655	1135x290x655
	Net/Gross weight	Kg	21.5/26	21.5/26	22/27	27/32	27/32
Refrigerant piping	Liquid side/ Gas side	mm	Φ6.35/ Φ12.7	Φ6.35/ Φ12.7	Φ6.35/ Φ12.7	Φ6.35/ Φ12.7	Φ9.53/ Φ15.9
Drainage Water Pipe Outer Diameter		mm	ODΦ32	ODΦ32	ODΦ32	ODΦ32	ODΦ32

Model Name			4TVD0024BB	4TVD0027BB	4TVD0030BB	4TVD0038BB	4TVD0048BB
Power supply		V-ph-Hz	220-240-1-50	220-240-1-50	220-240-1-50	220-240-1-50	220-240-1-50
Capacity	Cooling	kW	7.1	8	9	11.2	14
		Btu/hr	24,200	27,300	30,700	38,200	47,800
	Heating	kW	8	9	10	12.5	15.5
		Btu/hr	27,300	30,700	34,100	42,700	52,900
Rated Power		W	149	198	200	313	274
Rated Current		A	0.7	1	1	1.8	1.8
Air Flow (H/ M/ L)		m3/h	1050/905/821	1226/1018/861	1226/1018/861	1750/1552/1389	1918/1539/1250
Indoor External Static Pressure (H)		Pa	10(10-30)	20(10-50)	20(10-50)	40(10-80)	40(10-80)
Sound Level (H/ M/ L)		dB(A)	43.4/40/36	45.4/39.8/37	45.4/39.8/37	48.0/41.9/38	47.7/43.2/39.0
Indoor unit	Dimension (WxHxD)	mm	1010x270x635	1230x270x775	1230x270x775	1230x270x775	1290x300x865
	Packing (WxHxD)	mm	1135x350x655	1355x350x795	1355x350x795	1355x350x795	1400x375x925
	Net/Gross weight	Kg	30/34	38/46.5	40/48	40/48	49/58
Refrigerant piping	Liquid side/ Gas side	mm	Φ9.53/ Φ15.9	Φ9.53/Φ15.9	9.53/Φ15.9	Φ9.53/Φ15.9	Φ9.53/Φ15.9
Drainage Water Pipe Outer Diameter		mm	ODΦ32	ODΦ32	ODΦ32	ODΦ32	ODΦ32

Note:

- Nominal cooling capacities are based on the following conditions: return air temp.: 27 °C DB, 19 °C WB, outdoor temp.: 35 °C DB, equivalent ref. Piping: 7.5m (horizontal)
 - Nominal heating capacities are based on the following conditions: return air temp.: 20 °C DB, outdoor temp.: 7 °C DB, 6 °C WB, equivalent ref. Piping: 7.5m (horizontal)
 - Sound level is measured 1.4m below the air outlet
- * External static pressure are based on high speed indoor air flow
 * Specifications are subject to change without prior notice for product improvement

Indoor High Static Pressure Concealed Unit Series



• Wide Capacity Range

The capacity ranges from 24kBtu to 191kBtu including 12 models in total.

• Flexible Concealed Design

Four speed fan motor (medium high speed as an option only for 24~54 kBtu model).
External static pressure can be up to 196Pa (24~54 kBtu model) or 250Pa (68~191 kBtu model).
The maximum distance of air supply is about 14m, while the height of air supply is about 6.5m.
With 420mm (24~54 kBtu model) thickness body, the minimum distance above the ceiling is 450mm.

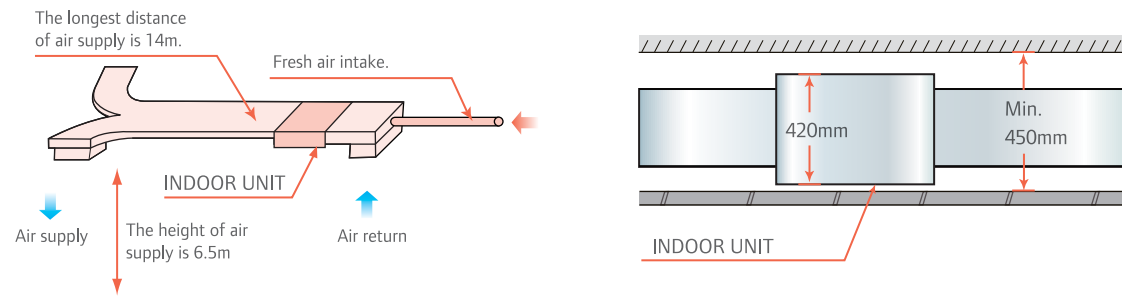

• Convenient Installation

The EXV is fixed inside the indoor unit (For 24~54 kBtu model), that leaves no need for extra connection.
Standard filter is placed in an aluminum frame, which can be removed downwards from the bottom.
Standard flange for air in/outlet duct connection is available.

• Flexible Control and Convenient Maintenance

It has a standard wired controller with a remote controller also available. The display board is connected with the E-box factory, which enables easier troubleshooting by LED display. Easy access filters both in the rear and bottom.
Standard functional ports such as Remote ON/OFF Dry contact switch and alarm signal output (220V) are also available.

• Option

Drain pumps with 750 mm pump head *(For 24~54 kBtu model) are also available as an optional accessory.

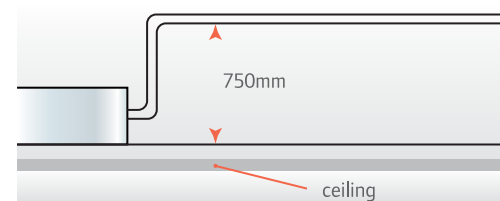

• Specifications

Model Name			4TVA0024BB	4TVA0027BB	4TVA0030BB	4TVA0038BB	4TVA0048BB	4TVA0055BB
Power supply		V-ph-Hz	220-240-1-50	220-240-1-50	220-240-1-50	220-240-1-50	220-240-1-50	220-240-1-50
Capacity	Cooling	kW	7.1	8	9	11.2	14	16
		Btu/hr	24,200	27,300	30,700	38,200	47,800	54,600
	Heating	kW	8	9	10	12.5	16	17
		Btu/hr	27,300	30,700	34,100	42,700	54,600	58,000
Rated Power		W	263	263	423	524	724	940
Rated Current		A	1.1	1.1	1.8	2.3	2.7	3.6
Air Flow (H/ M/ L)		m3/h	1400/1330/1210	1400/1330/1210	1940/1830/1515	2115/1940/1520	3000/2615/2230	3620/3060/2740
Indoor External Static Pressure (H)		Pa	40(30~196)	40(30~196)	40(30~196)	50(30~196)	50(30~196)	50(30~196)
Sound Level (H/ M/ L)		dB(A)	48/46/44	48/46/44.5	52/49/47	52/49/47	53/50/48	54/52/50
Indoor unit	Dimension (WxHxD)	mm	952x420x690	952x420x690	952x420x690	952x420x690	1200x400x600	1200x400x600
	Packing (WxHxD)	mm	1090x440x768	1090x440x768	1090x440x768	1090x440x768	1436x450x768	1436x450x768
	Net/Gross weight	Kg	45/50	45/50	46.5/52.4	50.6/56	68/70	70/77.5
Refrigerant piping	Liquid side/ Gas side	mm	Φ9.53/ Φ15.9	Φ9.53/ Φ15.9	Φ9.53/ Φ15.9	Φ9.53/ Φ15.9	Φ9.53/ Φ15.9	Φ9.53/ Φ15.9
Drainage Water Pipe Outer Diameter		mm	ODΦ32	ODΦ32	ODΦ32	ODΦ32	ODΦ32	ODΦ32

Model Name			4TVA0068BB	4TVA0085BB	4TVA0095BB	4TVA0136BB	4TVA0154BB	4TVA0191BB
Power supply		V-ph-Hz	220-240-1-50	220-240-1-50	220-240-1-50	220-240-1-50	220-240-1-50	220-240-1-50
Capacity	Cooling	kW	20	25	28	40	45	56
		Btu/hr	68,200	85,300	95,500	1,36,500	1,53,500	1,91,100
	Heating	kW	22.5	26	31.5	45	50	63
		Btu/hr	76,800	88,700	1,07,500	1,53,500	1,70,600	2,15,000
Rated Power		W	1516	1516	1516	2700	2700	3400
Rated Current		A	6.6	6.6	6.6	12.5	12.5	15.5
Air Flow (H/ M/ L)		m3/h	4665/4320/3625	4665/4320/3625	4665/4320/3625	7490/6120/5050	7490/6120/5050	9625/8050/6630
Indoor External Static Pressure (H)		Pa	140(50~250)	140(50~250)	140(50~250)	196(50~250)	196(50~250)	196(50~250)
Sound Level (H/ M/ L)		dB(A)	59/55/52	59/55/52	59/55/52	61/59/56	61/59/56	63/60/57
Indoor unit	Dimension (WxHxD)	mm	1443x470x810	1443x470x810	1443x470x810	1970x668x858.5	1970x668x858.5	1970x668x858.5
	Packing (WxHxD)	mm	1509x550x990	1509x550x990	1509x550x990	2095x800x964	2095x800x964	2095x800x964
	Net/Gross weight	Kg	115/129	115/129	115/129	232/245	232/245	232/245
Refrigerant piping	Liquid side/ Gas side	mm	Φ9.53/ Φ19.1 (x2)	Φ9.53/ Φ22.2(x2)	Φ9.53/ Φ22.2(x2)	Φ12.7/ Φ28.6(x2)	Φ12.7/ Φ28.6(x2)	Φ15.9/ Φ28.6(x2)
Drainage Water Pipe Outer Diameter		mm	ODΦ32	ODΦ32	ODΦ32	ODΦ32	ODΦ32	ODΦ32

Note:

- Nominal cooling capacities are based on the following conditions: return air temp.: 27 °C DB, 19 °C WB, outdoor temp.: 35 °C DB, equivalent ref. Piping: 7.5m (horizontal)
 - Nominal heating capacities are based on the following conditions: return air temp.: 20 °C DB, outdoor temp.: 7 °C DB, 6 °C WB, equivalent ref. Piping: 7.5m (horizontal)
 - Sound level is measured 1.4m below the air outlet
- * External static pressure are based on high speed indoor air flow
* Specifications are subject to change without prior notice for product improvement

Indoor Convertible Unit Series



• Installation Convenience

It can be easily installed into a corner of the ceiling even if the ceiling is very narrow. It is especially powerful when installed towards the center of the ceiling.

• Low Noise, creates Quiet and Comfortable Environment

Slim and sleek design with minimum weight (26Kg) guarantees quick, easy and neat installation. It operates at a low noise [lowest at 36dB(A)].

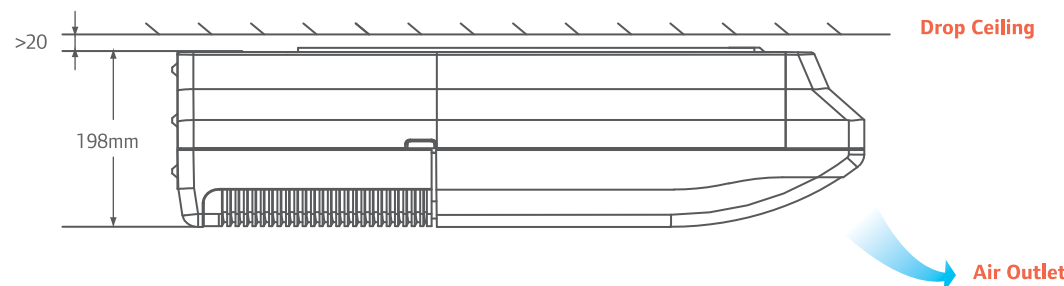
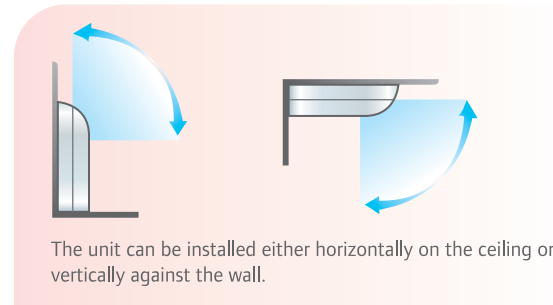

• Auto Swing and Wide Angle Air Flow

The unit has auto horizontal swing and auto vertical swing function, which supplies an even and comfortable airflow. It has three air flow speed: high/medium/low with double air guide. Adoption of the electronic expansion valve ensures precise flow control, as well as lower modulation noise when EXV is in operation. It allows smoother airflow with less turbulence, owing to the multiple-blade fan and the air guide design.

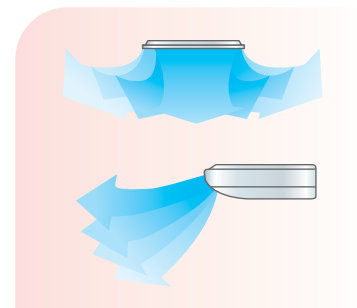

• Specifications

Model Name			4TVX0012BB	4TVX0015BB	4TVX0018BB	4TVX0024BB
Power supply		V-ph-Hz	220-240-1-50	220-240-1-50	220-240-1-50	220-240-1-50
Capacity	Cooling	kW	3.6	4.5	5.6	7.1
		Btu/hr	12,300	15,400	19,100	24,200
	Heating	kW	4	5	6.3	8
		Btu/hr	13,600	17,100	21,500	27,300
Rated Power		W	49	120	122	125
Rated Current		A	0.55	0.55	0.55	0.57
Air Flow (H/ M/ L)		m ³ /h	650/570/500	800/600/500	800/600/500	800/600/500
Sound Level (H/ M/ L)		dB(A)	40/38/36	43/41/38	43/41/38	43/41/38
Indoor unit	Dimension (WxHxD)	mm	990x660x206	990x660x206	990x660x206	990x660x206
	Packing (WxHxD)	mm	1089x744x296	1089x744x296	1089x744x296	1089x744x296
	Net/Gross weight	Kg	26/32	28/34	28/34	28/34
Refrigerant piping	Liquid side/ Gas side	mm	Φ6.35/ Φ12.7	Φ6.35/ Φ12.7	Φ9.53/ Φ15.9	Φ9.53/ Φ15.9
Drainage Water Pipe Outer Diameter		mm	ODΦ16	ODΦ16	ODΦ16	ODΦ16

Model Name			4TVX0027BB	4TVX0030BB	4TVX0038BB	4TVX0048BB
Power supply		V-ph-Hz	220-240-1-50	220-240-1-50	220-240-1-50	220-240-1-50
Capacity	Cooling	kW	8	9	11.2	14
		Btu/hr	27,300	30,700	38,200	47,800
	Heating	kW	9	10	12.5	15.5
		Btu/hr	30,700	34,100	42,700	52,900
Rated Power		W	130	130	182	182
Rated Current		A	0.6	0.6	0.83	0.83
Air Flow (H/ M/ L)		m ³ /h	1200/900/700	1200/900/700	1980/1860/1730	1980/1860/1730
Sound Level (H/ M/ L)		dB(A)	45/43/40	45/43/40	47/45/42	47/45/42
Indoor unit	Dimension (WxHxD)	mm	1280x660x206	1280x660x206	1670x680x244	1670x680x244
	Packing (WxHxD)	mm	1379x744x296	1379x744x296	1764x760x329	1764x760x329
	Net/Gross weight	Kg	34.5/41	34.5/41	54/59	54/59
Refrigerant piping	Liquid side/ Gas side	mm	Φ9.53/ Φ15.9	Φ9.53/ Φ15.9	Φ9.53/ Φ15.9	Φ9.53/ Φ15.9
Drainage Water Pipe Outer Diameter		mm	ODΦ16	ODΦ16	ODΦ16	ODΦ16

Note:

- Nominal cooling capacities are based on the following conditions: return air temp.: 27 °C DB, 19 °C WB, outdoor temp.: 35 °C DB, equivalent ref. Piping: 7.5m (horizontal)
 - Nominal heating capacities are based on the following conditions: return air temp.: 20 °C DB, outdoor temp.: 7 °C DB, 6 °C WB, equivalent ref. Piping: 7.5m (horizontal)
 - Sound level is measured 1.4m below the air outlet
- * External static pressure are based on high speed indoor air flow
 * Specifications are subject to change without prior notice for product improvement

Indoor High Wall Units



Q-Series (4 TVW)



R-Series (4TVI)

• Installation Convenience

Multi- refrigerant outlet pipe method: left/right/rear compact size, longer connection pipe: 468mm/Liquid pipe: 550mm and a newly designed fixing plate.

• Auto Swing Louver

Air direction can be tailored to the mode selected.

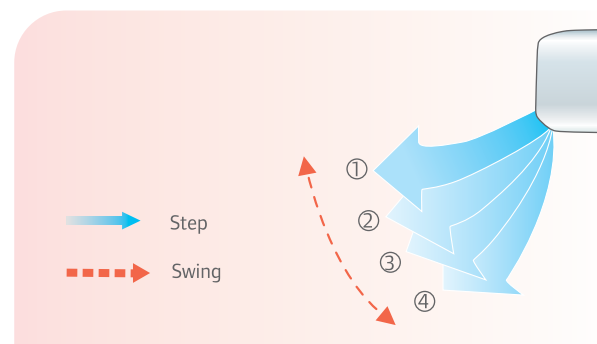

• Easy Maintenance

Removable front panel enables easy maintenance.

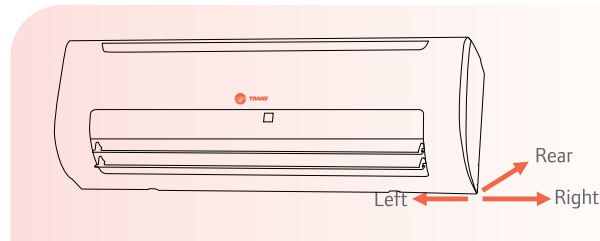
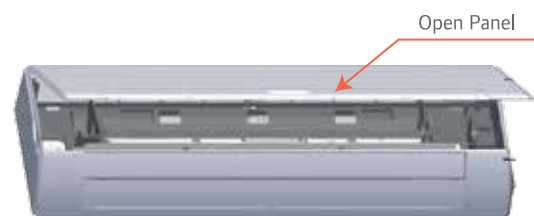

• Specifications

Model Name			4TVW0007BB	4TVW0009BB	4TVW0012BB	4TVW0015BB	4TVW0018BB	4TVW0024BB	4TVW0027BB	
Power supply		V-ph-Hz	220-240-1-50	220-240-1-50	220-240-1-50	220-240-1-50	220-240-1-50	220-240-1-50	220-240-1-50	
Capacity	Cooling	kW	2.2	2.8	3.6	4.5	5.6	7.1	8	
		Btu/hr	7,500	9,600	12,300	15,400	19,100	24,200	27,300	
	Heating	kW	2.6	3.2	4	5	6.3	8	9	
		Btu/hr	8,900	10,900	13,600	17,100	21,500	27,300	30,700	
Rated Power		W	28	28	28	45	45	79	86	
Rated Current		A	0.14	0.14	0.14	0.2	0.2	0.33	0.39	
Air Flow (H/ M/ L)		m ³ /h	520/480/430	520/480/430	520/480/430	860/755/630	925/860/755	1190/880/680	1320/840/640	
Sound Level (H/ M/ L)		dB(A)	35/32/29	35/32/29	35/32/29	40/38/34	40/38/34	47/43/42	48/43/38	
Indoor unit	Dimension (WxHxD)		mm	915×290×210	915×290×210	915×290×210	1070×315×210	1070×315×210	1250×325×245	1250×325×245
	Packing (WxHxD)		mm	1020×385×300	1020×385×300	1020×385×300	1165×395×285	1165×395×285	1345×335×430	1345×335×430
	Net/Gross weight		Kg	12/16	12/16	12/16	16/19	16/19	19.9/25	19.9/25
Refrigerant piping	Liquid side/ Gas side	mm	Φ6.35/ Φ12.7	Φ6.35/ Φ12.7	Φ6.35/ Φ12.7	Φ6.35/ Φ12.7	Φ9.53/Φ15.9	Φ9.53/Φ15.9	Φ9.53/Φ15.9	
Drainage Water Pipe Outer Diameter		mm	ODΦ16	ODΦ16	ODΦ16	ODΦ16	ODΦ16	ODΦ16	ODΦ16	

Model Name			4TVW00031BB	4TVI0007BB	4TVI0009BB	4TVI0012BB	4TVI0015BB	4TVI0018BB	
Power supply		V-ph-Hz	220-240-1-50	220-240-1-50	220-240-1-50	220-240-1-50	220-240-1-50	220-240-1-50	
Capacity	Cooling	kW	9	2.2	2.8	3.6	4.5	5.6	
		Btu/hr	30,700	7,500	9,600	12,300	15,400	19,100	
	Heating	kW	10	2.6	3.2	4	5	6.3	
		Btu/hr	34,100	8,900	10,900	13,600	17,100	21,500	
Rated Power		W	86	28	28	28	45	45	
Rated Current		A	0.39	0.14	0.14	0.14	0.2	0.2	
Air Flow (H/ M/ L)		m ³ /h	1320/840/640	525/480/430	525/480/430	590/520/480	860/755/630	925/860/755	
Sound Level (H/ M/ L)		dB(A)	49/43/38	35/32/29	35/32/29	35/32/29	40/38/34	40/38/34	
Indoor unit	Dimension (WxHxD)		mm	1250×325×245	915×290×230	915×290×230	915×290×230	1072×315×230	1072×315×230
	Packing (WxHxD)		mm	1345×335×430	1020×390×315	1020×390×315	1020×390×315	1180×415×315	1180×415×315
	Net/Gross weight		Kg	19.9/25	13/16.5	13/16.5	13/16.5	15.1/18.8	15.1/18.8
Refrigerant piping	Liquid side/ Gas side	mm	Φ9.53/Φ15.9	Φ6.35/ Φ12.7	Φ6.35/ Φ12.7	Φ6.35/ Φ12.7	Φ6.35/ Φ12.7	Φ9.53/Φ15.9	
Drainage Water Pipe Outer Diameter		mm	ODΦ16	ODΦ16	ODΦ16	ODΦ16	ODΦ16	ODΦ16	

Note:

- Nominal cooling capacities are based on the following conditions: return air temp.: 27 °C DB, 19 °C WB, outdoor temp.: 35 °C DB, equivalent ref. Piping: 7.5m (horizontal)
- Nominal heating capacities are based on the following conditions: return air temp.: 20 °C DB, outdoor temp.: 7 °C DB, 6 °C WB, equivalent ref. Piping: 7.5m (horizontal)
- Sound level is measured 1m below the air outlet

* Specifications are subject to change without prior notice for product improvement

Fresh Air Processing Unit

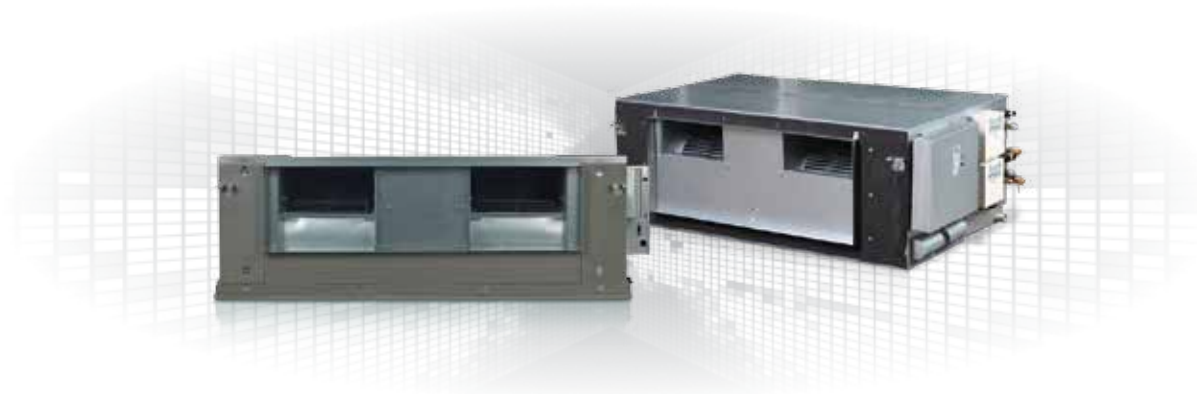

- **Comfortable and Healthy Environment**

Fresh air creates comfortable and healthy environment.

- **100% Fresh Air Processing Unit**

In a single system, both, fresh air filtration and heating/cooling can be achieved conveniently. Indoor units and fresh air processing unit can be connected to the same refrigerant system, which results in enhanced design flexibility and a significant reduction in total system costs.

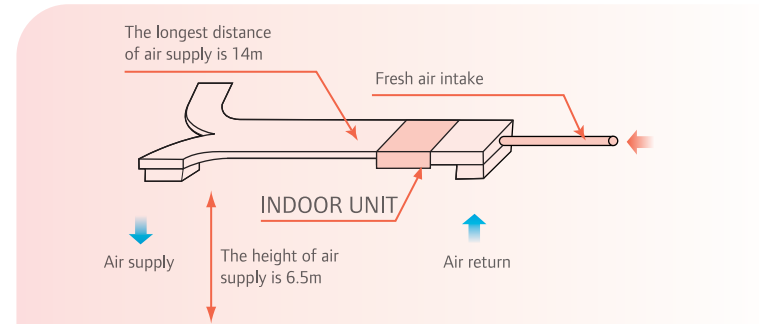

- **High External Static pressure**

High external static pressure ensures more flexible duct application, up to 220Pa (42~48KBtu model) and 260Pa (68~95KBtu model).
The maximum distance of air supply is up to 14m and maximum height of air supply is up to 6.5m.

- **Innovative Air Supply Technology for Excellent Room Temperature Control**

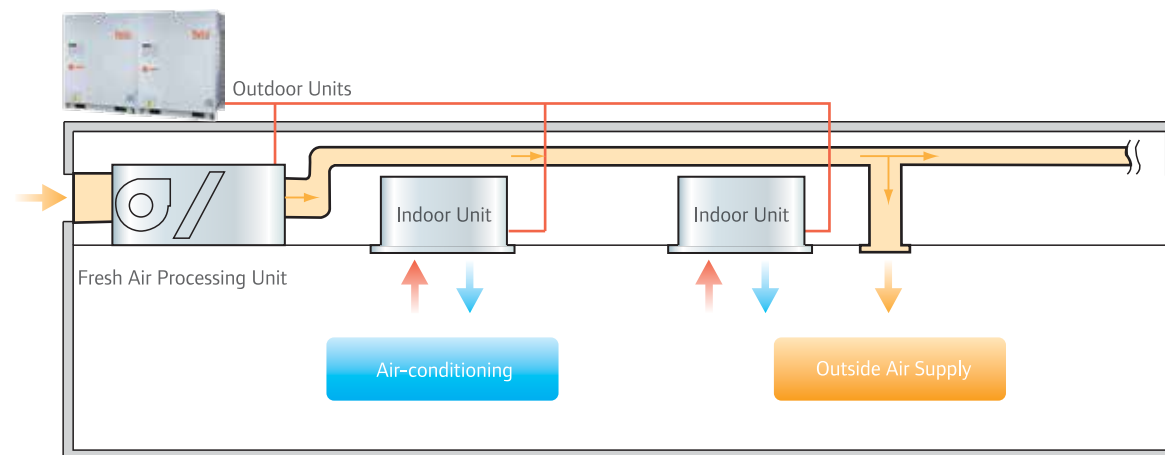

- **Specifications**

Model Name			4TVF0042BB	4TVF0048BB	4TVF0068BB	4TVF0085BB	4TVF0095BB
Power supply		V-ph-Hz	220-240-1-50	220-240-1-50	220-240-1-50	220-240-1-50	220-240-1-50
Capacity	Cooling	kW	12.5	14	20	25	28
		Btu/hr	42,700	47,800	68,200	85,300	95,500
	Heating	kW	10.5	12	18	20	22
		Btu/hr	35,800	40,900	61,400	68,200	75,100
Rated Power		W	430	430	1000(x2)	1063(x2)	1063(x2)
Rated Current		A	2.4	2.4	5.3	5.6	5.6
Air Flow (H/ M/ L)		m3/h	520/480/430	520/480/430	520/480/430	860/755/630	925/860/755
Indoor External Static Pressure (H)		Pa	30-220	30-220	50-260	50-260	50-260
Sound Level (H/ M/ L)		dB(A)	54/52/50	54/52/50	54/53/51	55/54/52	55/54/52
Indoor unit	Dimension (WxHxD)	mm	1368x420x691	1368x420x691	1443x470x810	1443x470x810	1443x470x810
	Packing (WxHxD)	mm	1436x440x768	1436x440x768	1509x522x964	1509x522x964	1509x522x964
	Net/Gross weight	Kg	69.5/76	69.5/76	115/125	115/125	115/125
Refrigerant piping	Liquid side/ Gas side	mm	Φ9.52/Φ16	Φ9.52/Φ16	Φ9.52/Φ16	Φ9.52/Φ16	Φ9.52/Φ16
Drainage Water Pipe Outer Diameter		mm	ODΦ25	ODΦ25	ODΦ32	ODΦ32	ODΦ32

Note:

1. Nominal cooling capacities are based on the following conditions: outdoor air temp.: 33 °C DB, 24 °C WB, equivalent ref. Piping: 7.5m (horizontal)
2. Nominal heating capacities are based on the following conditions: outdoor air temp.: 0 °C DB, -1 °C WB, equivalent ref. Piping: 7.5m (horizontal)
3. Sound level is measured 1.4m below the air outlet

*external static pressure are based on high speed indoor air flow

* Specifications are subject to change without prior notice for product improvement

Connection Conditions:

The following restrictions must be observed in order to maintain the indoor units connected to the same system.

* When fresh air processing units are connected, the total connection capacity must be within 50% to 100% of that of the outdoor units.

* When fresh air processing units and standard indoor units are connected, the total connection capacity of the fresh air processing units must not exceed 30% of that of the outdoor units.

* Fresh air processing units can be used without indoor units.

Intelligent Management Control System

The TVR™ II system can be controlled at different user levels, from the individual user level with the zone controllers to a more centralized tenant by tenant control, or a fully integrated building control PC system with a third party BMS control system.

Individual Controllers

Wireless Controller

- Functions: LCD display, Clock, ON/ OFF, Temp. setting, Mode setting, Fan speed setting, Timer, Horizontal Swing, Vertical Swing, Air Direction
- Mode: Auto/Dry/Cool/Heat & Fan only
- Timer: 0 - 24 hrs timer setting
- Addressing function



Wired Controller

- Functions: LCD display, ON/OFF, temp. setting, Mode setting, Fan speed setting, Timer, Swing setting, Lock
- Mode: Auto/Dry/Cool/Heat & Fan only
- Timer: 0 - 24 hrs timer setting
- Follow me: Allows precise room temperature control using the Temperature sensor in the controller



Centralized Controllers

Indoor unit Centralized Controller

- Functions: Centralized ON/OFF mode setting, Temperature setting, Fan setting, Mode lock function
- Set weekly schedule
- Blue lit background LCD
- Lock mode
- RS232 connection to PC



Outdoor unit Centralized Controller

- Functions: Centralized ON/OFF, Mode query, Temp. query, Fan query, Mode lock function
- Controls 32 outdoor units and a PC can control 16 OU centralized controllers
- This controller cannot be connected directly to Mini TVR™ II units.
- Blue lit background LCD
- Emergency stop contact or forced cooling start signal
- Maximum wiring length 1,000m
- RS 232 interface to TVR™ II system PC control



New Service Software

As part of our new TVR™ II portfolio, we introduce a new service tool that allows you to diagnose and troubleshoot the system.

- Real time display of outdoor unit operating parameters
- Description of error codes

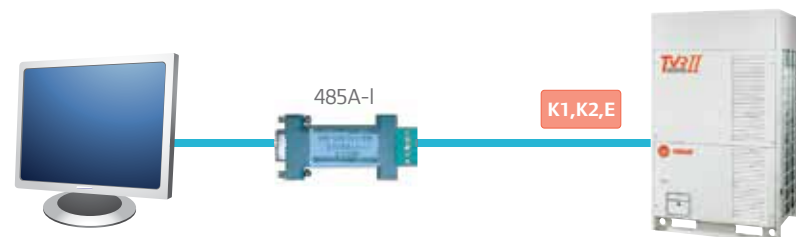

Building Management Control

The TVR™ II control network can combine several centralized controllers with a PC (or external BMS systems such as Tracer SC) through BACnet™ or MODBUS interfaces to meet customers' needs in different applications. This higher level of control adds more user friendly features such as power consumption reporting.

TVR II PC Network control software

- Up to 1,200m of wiring can be extended to 3,000m with signal booster relay
- Monitors the system online, records operation data, reports errors
- Manages up to 16 Outdoor and 16 Indoor centralized controllers or up to 1,024 indoor units and 512 Outdoor Units
- Compatible with Windows XP
- Remote online service access possible through internet
- Power consumption report (requires additional external Watt meters)



BACnet® Interface

- This gateway connects through BACnet® to the TVR™ II entire installation and other external components through an existing BMS
- Connects through Ethernet to BACnet®/IP
- 4 RS485 connections for connecting to 4 TVR II centralized controllers (BACnet® is a registered trademark of ASHRAE).

Digital Ampmeter

- One Amp meter per Master Outdoor Unit or condensing system
- Needs to be connected to specific wiring terminals on outdoor unit
- Outdoor Units TVR II need to have a centralized controller that connects to PC or network.



MODBUS Interface

- Integrates TVR II systems to BMS systems through MODBUS.
- Controls up to 1024 indoor units and 64 outdoor units
- Transfers the information via the RTU mode
- Wide voltage 12-48VDC



BMS Lonworks Gateway

- Enables centralized control of up to 1024 indoor units and 512 outdoor units to the LonWorks BMS.
- Easily connectable to the BMS system.
- Ideal module for scattered units in large projects.

Other Accessories

Trane also offers other accessories to maximize customers' comfort in different applications.



Air Handler (AHU) Connection Kit

This kit allows you to integrate other indoor units to the TVR II system. The kit includes the control boards, EXV, sensors, and wired controller.



Motion Sensor

• Turns off the system when it doesn't sense movement in the room.



Hotel Inserting Card

- ON-OFF control
- Auto-restart function